

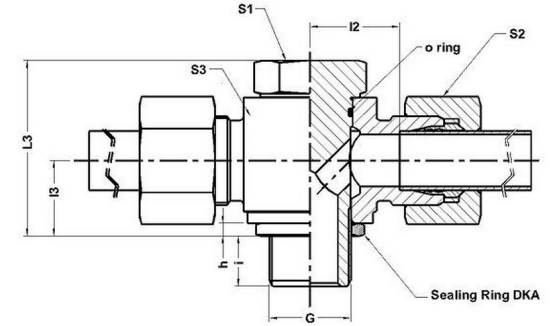

HYDROMATIK
connections par excellence

Metric Bite Type Fittings

TWH-M - HIGH PRESSURE TEE BANJO COUPLING TWH-M

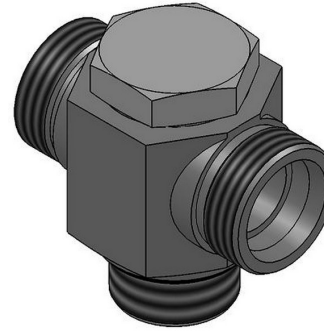

Part No.	Series	Tube OD	G	i	l2	l3	L3	S1	S2	S3	h
TWH 06-LM	Light-250 Bar	6	M10 X 1.0	8	12	10.5	24	17	14	17	2.5
TWH 08-LM	Light-250 Bar	8	M12 X 1.5	12	14.5	14	30	19	17	22	3
TWH 10-LM	Light-250 Bar	10	M14 X 1.5	12	15.5	14	30	19	19	22	3
TWH 12-LM	Light-250 Bar	12	M16 X 1.5	12	18	16.5	36	24	22	27	3
TWH 15-LM	Light-250 Bar	15	M18 X 1.5	12	21.5	18.5	39.5	30	27	32	4.5
TWH 18-LM	Light-160 Bar	18	M22 X 1.5	14	21	21.5	45	30	32	32	4.5
TWH 22-LM	Light-160 Bar	22	M26 X 1.5	16	27.5	24	53	36	36	41	3.5
TWH 28-LM	Light-100 Bar	28	M33 X 2.0	18	32	30.5	66	46	41	50	3.5
TWH 35-LM	Light-100 Bar	35	M42 X 2.0	20	36	35.5	76	55	50	60	3.5

TWH 42-LM	Light-100 Bar	42	M48 X 2.0	22	40.5	40.5	87	60	60	70	3.5
TWH 06-SM	Heavy-630 Bar	6	M12 X 1.5	12	16.5	14	30	19	17	22	3
TWH 08-SM	Heavy-630 Bar	8	M14 X 1.5	12	16.5	14	30	19	19	22	3
TWH 10-SM	Heavy-630 Bar	10	M16 X 1.5	12	18.5	16.5	36	24	22	27	3
TWH 12-SM	Heavy-630 Bar	12	M18 X 1.5	12	18.5	18.5	39.5	24	24	27	3
TWH 14-SM	Heavy-630 Bar	14	M20 X 1.5	14	22.5	20	43.5	30	27	32	3
TWH 16-SM	Heavy-400 Bar	16	M22 X 1.5	14	22	21.5	45	30	30	32	4.5
TWH 20-SM	Heavy-400 Bar	20	M27 X 2.0	16	26.5	24	53	36	36	41	3.5
TWH 25-SM	Heavy-400 Bar	25	M33 X 2.0	18	31.5	30.5	66	46	46	50	3.5
TWH 30-SM	Heavy-250 Bar	30	M42 X 2.0	20	37	35.5	76	55	50	60	3.5
TWH 38-SM	Heavy-250 Bar	38	M48 X 2.0	22	41.5	40.5	87	60	60	70	3.5

Dimensions given approx.. fig. with tightened nut