



HYDROMATIK
connections par excellence

Metric Bite Type Fittings

GE-LR - STRAIGHT MALE STUD COUPLING GE-LR | Male

Stud Thread G - BSP

BSP Threads Parallel Form 'A'

(On Request Form 'B' also Available)

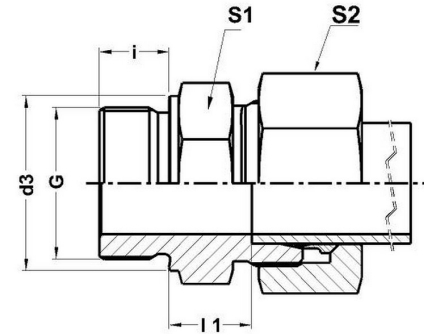

Part No.	Series	Tube OD	l1	i	S2	S1	d3	G
GE 06 LR	Light-250 Bar	6	8.5	8	14	14	14	G 1/8
GE 06 LR	Light-250 Bar	6	10	12	14	19	18.9	G 1/4
GE 06 LR	Light-250 Bar	6	11.5	12	14	22	22	G 3/8
GE 06 LR	Light-250 Bar	6	12	14	14	27	26.9	G 1/2
GE 08 LR	Light-250 Bar	8	10	12	17	19	18	G 1/4
GE 08 LR	Light-250 Bar	8	9.5	8	17	14	14	G 1/8
GE 08 LR	Light-250 Bar	8	11.5	12	17	22	22	G 3/8
GE 08 LR	Light-250 Bar	8	12	14	17	27	26.9	G 1/2
GE 10 LR	Light-250 Bar	10	11	12	19	19	18	G 1/4
GE 10 LR	Light-250 Bar	10	12.5	12	19	22	22	G 3/8
GE 10 LR	Light-250 Bar	10	13	14	19	27	26	G 1/2
GE 12 LR	Light-250 Bar	12	12.5	12	22	22	22	G 3/8
GE 12 LR	Light-250 Bar	12	12	12	22	19	18	G 1/4

GE 12 LR	Light-250 Bar	12	13	14	22	27	26	G 1/2
GE 12 LR	Light-250 Bar	12	14	16	22	32	32	G 3/4
GE 15 LR	Light-250 Bar	15	14	14	27	27	26	G 1/2
GE 15 LR	Light-250 Bar	15	13.5	12	27	22	22	G 3/8
GE 15 LR	Light-250 Bar	15	15	16	27	32	32	G 3/4
GE 18 LR	Light-160 Bar	18	14.5	14	32	27	26	G 1/2
GE 18 LR	Light-160 Bar	18	14	12	32	27	22	G 3/8
GE 18 LR	Light-160 Bar	18	14.5	16	32	32	32	G 3/4
GE 22 LR	Light-160 Bar	22	16.5	16	36	32	32	G 3/4
GE 22 LR	Light-160 Bar	22	16.5	14	36	32	26	G 1/2
GE 22 LR	Light-160 Bar	22	17.5	18	36	41	39	G 1
GE 28 LR	Light-100 Bar	28	17.5	18	41	41	39	G 1
GE 28 LR	Light-100 Bar	28	17.5	16	41	41	32	G 3/4
GE 35 LR	Light-100 Bar	35	17.5	20	50	50	49	G 1.1/4
GE 35 LR	Light-100 Bar	35	17.5	18	50	50	39	G 1
GE 42 LR	Light-100 Bar	42	19	22	60	55	55	G 1.1/2

Dimensions given approx. Fig. with tightened nut.

Part No. Given refers to complete assembly - Steel Part