

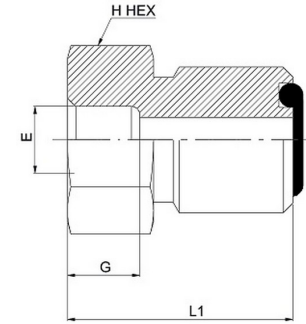

**HYDROMATIK**  
connections par excellence

## O-Ring Face Seal Fittings

**Bore-MFS Straight FS0403 Series** | SAE# 520104

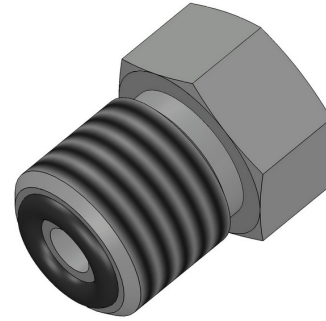

PART NO.SIZE	E* BORE	A THREAD	A DRILL	G* DEPTH	L1 LGTH	H HEX
FS0403-04-04	0.256	9/16-18	0.172	0.330	0.86	0.625
FS0403-04-06	0.256	11/16-16	0.264	0.330	0.90	0.750
FS0403-06-04	0.381	9/16-18	0.172	0.330	0.86	0.750
FS0403-06-06	0.381	11/16-16	0.264	0.330	0.90	0.750
FS0403-06-08	0.381	13/16-16	0.378	0.330	0.97	0.875
FS0403-08-06	0.506	11/16-16	0.264	0.330	0.90	0.875
FS0403-08-08	0.506	13/16-16	0.378	0.330	0.97	0.875
FS0403-08-10	0.506	1-14	0.484	0.330	1.07	1.062
FS0403-08-12	0.506	1-3/16-12	0.609	0.330	1.16	1.250
FS0403-10-08	0.631	13/16-16	0.378	0.330	0.97	1.062
FS0403-10-10	0.631	1-14	0.484	0.330	1.07	1.062
FS0403-10-12	0.631	1-3/16-12	0.609	0.330	1.16	1.250
FS0403-12-08	0.757	13/16-16	0.378	0.490	1.13	1.250
FS0403-12-10	0.757	1-14	0.484	0.490	1.23	1.250
FS0403-12-12	0.757	1-3/16-12	0.609	0.490	1.32	1.250

FS0403-12-16	0.757	1-7/16-12	0.811	0.490	1.46	1.500
FS0403-16-12	1.007	1-3/16-12	0.609	0.550	1.38	1.500
FS0403-16-16	1.007	1-7/16-12	0.811	0.550	1.52	1.500
FS0403-16-20	1.007	1-11/16-12	1.024	0.550	1.52	1.750
FS0403-20-20	1.258	1-11/16-12	1.024	0.550	1.52	1.750
FS0403-20-24	1.258	2-12	1.260	0.550	1.52	2.125
FS0403-24-20	1.508	1-11/16-12	1.024	0.550	1.52	2.125
FS0403-24-24	1.508	2-12	1.260	0.550	1.52	2.125

\*E,G dimensions are for silver brazing.(SAE J1453)